



Engine Crane

Operating Instructions & Parts Manual

Model

HW93806

Maximum Rated Capacity
(based on leg & boom extension position)

3 Tons

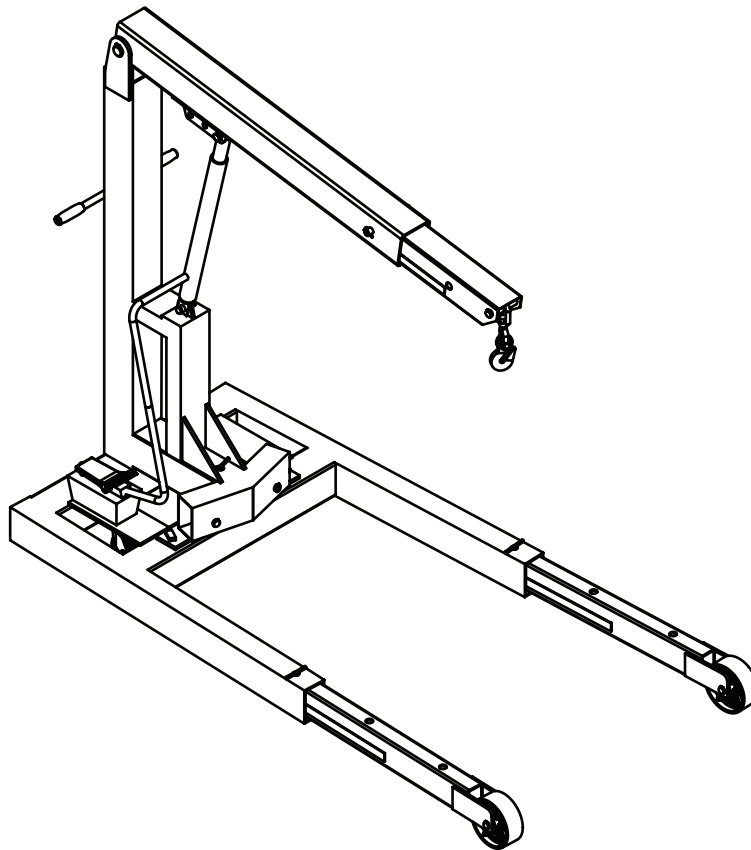

This is the safety alert symbol. It is used to alert you to potential personal injury hazards. Obey all safety messages that follow this symbol to avoid possible injury or death.

SFA Companies ©2008
10939 N. Pomona Ave. Kansas City, MO 64153
816-891-6390
customerservices@heinwerner-automotive.com

TABLE OF CONTENTS

Warranty	Pg. 2
Save These Instructions	Pg. 3
Product Description & Specifications	Pg. 3
Assembly / Before Use	Pg. 4
Safety Instructions	Pg. 5
Operation	Pg. 5
Maintenance	Pg. 6
Troubleshooting	Pg. 7
Replacement Parts	Pg. 8



TWO YEARS LIMITED WARRANTY

For a period of two (2) years from date of purchase, SFA Companies will repair or replace, at its option, without charge, any of its products which fails due to a defect in material or workmanship under normal usage. This limited warranty is a consumer's exclusive remedy.

Performance of any obligation under this warranty may be obtained by returning the warranted product, freight prepaid, to SFA Companies Warranty Service Department, 10939 N. Pomona Ave., Kansas City, MO 64153.

Except where such limitations and exclusions are specifically prohibited by applicable law:

- (1) THE CONSUMER'S SOLE AND EXCLUSIVE REMEDY SHALL BE THE REPAIR OR REPLACEMENT OF DEFECTIVE PRODUCTS AS DESCRIBED ABOVE
- (2) SFA COMPANIES SHALL NOT BE LIABLE FOR ANY CONSEQUENTIAL OR INCIDENTAL DAMAGE OR LOSS WHATSOEVER.
- (3) ANY IMPLIED WARRANTIES, INCLUDING WITHOUT LIMITATION THE IMPLIED WARRANTIES OF MERCHANTABILITY AND FITNESS FOR A PARTICULAR PURPOSE, SHALL BE LIMITED TO TWO YEARS, OTHERWISE THE REPAIR, REPLACEMENT OR REFUND AS PROVIDED UNDER THIS EXPRESS LIMITED WARRANTY IS THE EXCLUSIVE REMEDY OF THE CONSUMER, AND IS PROVIDED IN LIEU OF ALL OTHER WARRANTIES, EXPRESS OR IMPLIED.
- (4) ANY MODIFICATION, ALTERATION, ABUSE, UNAUTHORIZED SERVICE OR ORNAMENTAL DESIGN VOIDS THIS WARRANTY AND IS NOT COVERED BY THIS WARRANTY.

Some states do not allow limitations on how long an implied warranty lasts, so the above limitation may not apply to you. Some states do not allow the exclusion or limitation of incidental or consequential damages, so the above limitation or exclusion may not apply to you. This warranty gives you specific legal rights, and you may also have other rights which vary from state to state.

SAVE THESE INSTRUCTIONS

For your safety, *read, understand, and follow* the information contained in this manual. The owner and operator shall have an understanding of this product and safe operating procedures before attempting use. Instructions and safety information shall be conveyed in the operator's native language before use of this product is authorized. Make certain that the operator thoroughly understands the potential dangers associated with the use and misuse of the product. If any doubt exists as to the safe and proper use of this product as outlined in this factory authorized manual, remove from service immediately.

Inspect before each use. Do not use if there are broken, bent, cracked or otherwise damaged parts (including labels). If the engine crane has been or suspected to have been subjected to a shock load (a load dropped suddenly and unexpectedly upon it), discontinue use until inspected by a Hein-Werner authorized factory service center. Owners and operators of this equipment shall be aware that the use of this equipment may require special training and knowledge. It is recommended that an annual inspection be done by qualified personnel and that any missing or damaged parts, decals, warning/safety labels or signs be replaced with factory authorized replacement parts only. Any engine crane that appears to be damaged in any way, is worn or operating abnormally shall be removed from service immediately. Labels and Operator's Manual are available from manufacturer.

PRODUCT DESCRIPTION

This Hein-Werner Engine Crane is designed to safely lift, lower, and transport in the lowest position, rated capacity engines. HW93806 comes with leg and boom extension sections that can extend, retract, and lock in position.



*A **minimum** of 2 people are required to perform the following crane functions:*

- a. move loaded crane.*
- b. adjust **unloaded** boom.*
- c. adjust **unloaded** leg extension.*

***Never** attempt to move crane, adjust leg or boom extensions unassisted.*

SPECIFICATIONS

Model	Boom Capacity @ Length	Hook Height		Leg Extension	Stored Dimension				Wheel Dia.		G.W.
		Min.	Max.		Height	Rear Width	Front Width	Length	Front	Rear	
HW93806	3 Ton	30-1/2"	120-1/2"	91-1/4"	88-1/2"	45-1/4"	51"	75"	8"	6"	1150 lbs.
	2-1/2 Ton	18-1/2"	128-1/2"	106-3/4"							
	2 Ton	6-1/2"	144-1/2"	123"							

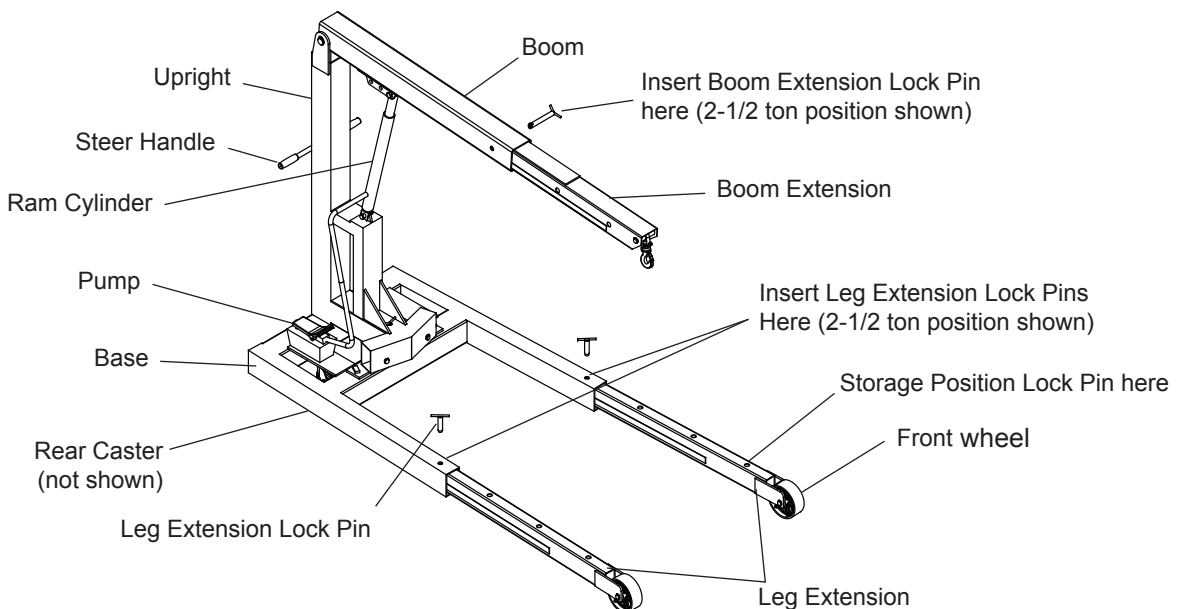

Figure 2: Model HW93806 Components

ASSEMBLY (refer to Fig. 2, 3, 4, 5 and 6)

1. Unpack the hydraulic pump, remove the shipping plug (red) and replace with vented plug (black).
2. Place the pump onto the pump pad, orient the pump so that the air hose connection is at **rear** of crane.
3. Connect shop air hose (not included) to the threaded port at the rear of pump.
4. Assemble and install shackle axle components into boom extension. Attach swivel hook assy to shackle (Fig. 6)



A **minimum** of 2 people are required to perform the following crane functions:

- a. move loaded crane.
- b. adjust **unloaded** boom.
- c. adjust **unloaded** leg extension.

Do not attempt to move crane, adjust leg or boom extensions unassisted.

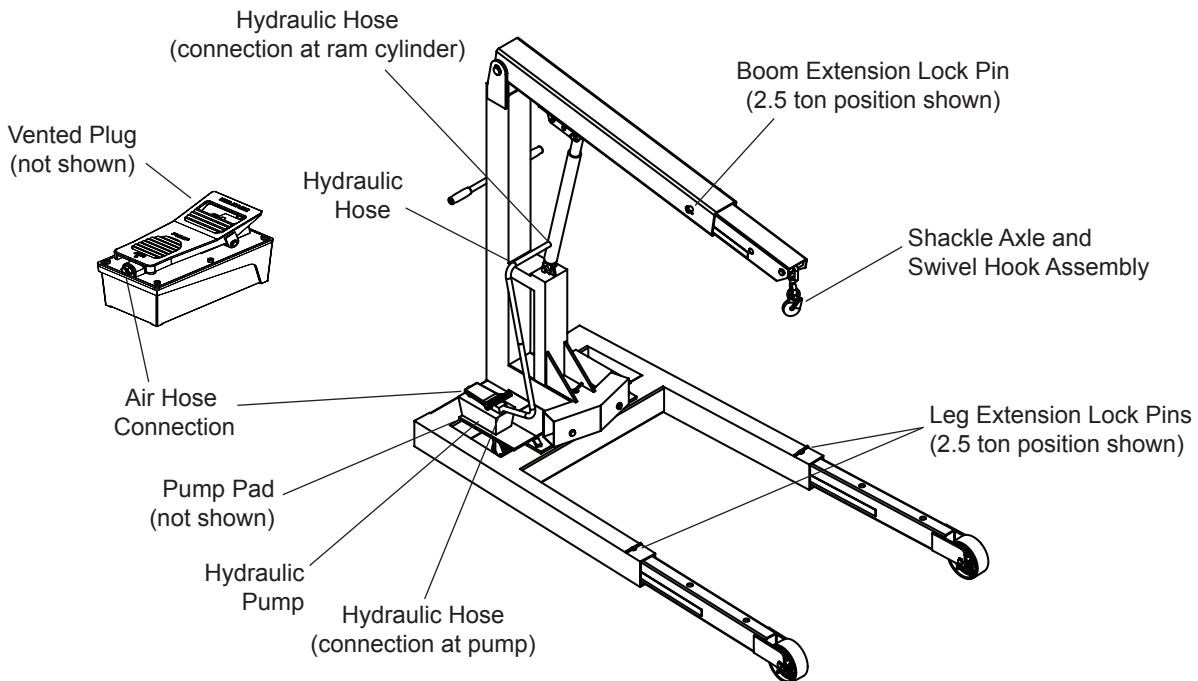

Figure 3: Assembly Illustration for Model HW93806

BEFORE USE

Hydraulic Pump:

1. Remove plug from air hose connection, connect to air supply (connection is 1/4" NPT) capable of providing 7.8 CFM @ 175 psi.
2. Remove plug from hydraulic hose connection, then connect to hydraulic hose connection at ram cylinder.
3. Familiarize yourself with the operation of the pump. To operate pump, press on the horizontal portion of the foot-pedal until desired pressure, load or position is reached. Always monitor pressure, load or position using suitable equipment. Pressure may be monitored by means of an optional manifold and gauge.
4. To lower the load, slowly & carefully press the release valve by stepping on the raised, stirrup shaped portion of the foot pedal.



Do not attempt to adjust leg or boom extensions when crane is loaded.

Crane:

1. Inspect crane before each use. Do not use if bent, broken or cracked components are noted. Ensure that casters/wheels and boom move freely. Check for and tighten any loose assemblies.
2. Verify that the product and the application are compatible, if in doubt call **Hein-Werner Technical Service** (816) 891-6390.
3. Before using this product, read this manual completely and familiarize yourself thoroughly with the product and its components, and recognize potential hazards associated with its use.



Before use, determine weight of load. Adjust boom and legs to a capacity greater than load.

WARNING

- **Study, understand, and follow all instructions** provided with/on this device **before use**.
- After removing, immediately transfer the engine to an appropriately rated work station such as an engine stand.
- **Do not** exceed rated capacity. **Do not** exceed rated capacity for each boom and leg position.
- Use only on hard, level surface.
- **Before** moving a loaded crane, make certain that load is stable, in its **lowest possible position**, and is moved over a smooth, hard level surface.
- Use of this engine crane is limited to the lifting, lowering, and transporting in the lowest possible position, automotive and light truck engines. It is not a work station and should never be used as a work station.
- Off center loading may cause the engine to tip unexpectedly and cause the loaded crane to tip over.
- Do not allow load to swing or drop violently while lowering or moving.
- Only attachments and/or adapters supplied by the manufacturer shall be used.
- No alterations shall be made to this product.
- **Failure to heed** these warnings may result in **personal injury and/or property damage**.



Always wear appropriate safety gear, including safety goggles, when working with or around high-pressure hydraulic equipment.

WARNING

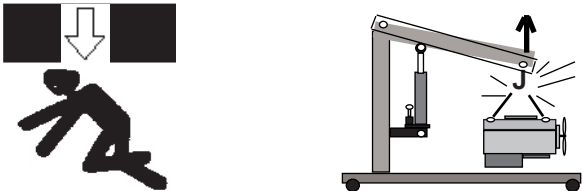

To avoid crushing and related injuries:

- **Do not** work on, under or around a loaded crane.
- **Immediately** transfer the load to an appropriately rated engine stand.
- **Be alert** and **sober** when using this product. **Never** operate this equipment when under the influence of drugs or alcohol.
- **Do not** place yourself or anyone else over the loaded boom or in its line of travel.
- Use **only** hardened, appropriately sized fasteners to secure engine to crane.
- Use **only** chains and slings with a **capacity equal to or greater** than that of the crane.
- **Never** adjust boom extension beyond leg extension.

OPERATION

! *Do not put any portion of your body under the load when it is supported by the engine crane.*

! *Verify that the crane and the application are compatible. Do not load crane with an engine that extends beyond an imaginary line connecting the centerlines of the front and rear wheels/caster axles as shown on right in Fig. 4.*

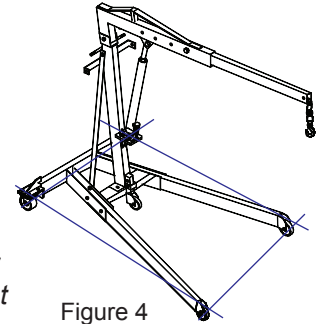

Figure 4

! *Lift only on areas of the engine specified by the vehicle manufacturer.*

1. Ensure load does not exceed rated capacity of chosen boom/leg adjustment. Leg capacity marking **must** match boom extension capacity marking. **Do not** extend boom extension beyond leg extension.
2. Secure appropriately rated engine leveler, chain or sling assembly (not included) to the vehicle manufacturer's recommended engine lift points.
3. Secure engine crane hook assembly to engine leveler, chain or sling assembly.
4. Refer to vehicle service manual/shop manual for location of appropriate engine lift points and removal procedures. Different engine removal/installation procedures may require different tools and levels of expertise.
5. When ready to remove engine, press horizontal portion of pump pedal until load is high enough to clear vehicle (see Fig. 5).
6. When clear of engine compartment, immediately transfer engine to an appropriate work stand. Lower engine by carefully pressing stirrup shaped portion of pedal.

! *Ensure all tools and personnel are clear before lowering load.*

Note: If necessary, reposition loaded engine stand only across smooth, level surface with assistance from additional personnel. Before moving, ensure the load is:
a) lowered to the lowest practical position by turning the release valve counter-clockwise slowly and carefully,
b) prevented from swinging and inadvertent shifting.

7. Ensure stand is secure before working on or around.

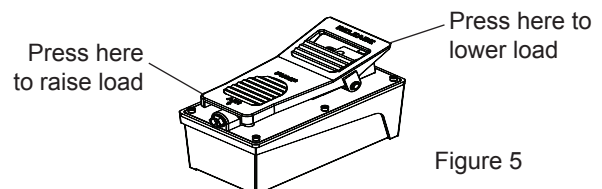

Figure 5



MAINTENANCE (Hydraulic Pump)

1. Inspect hoses and connections daily. Replace damaged components immediately with Hein-Werner replacement parts only.
2. Tighten connections as needed. Use non-hardening pipe thread compound when servicing connections.

Adding Hydraulic Fluid

1. Depressurize and disconnect hydraulic hose from ram.
2. With pump in its upright, horizontal position, remove the air vent plug located on the top plate of the reservoir.
3. Use a small funnel to fill reservoir to within 3/4" (19mm) of the opening.

Note: Use only HW93291 hydraulic oil or equivalent. **Never** use brake fluid, transmission fluid, turbine oil, motor oil, alcohol, glycerin etc. Use of other than good quality hydraulic oil will void warranty and damage the pump, hose, and application.

4. Wipe up any spilled fluid and reinstall the air vent plug.

Changing Hydraulic Fluid

For best performance and longest life, replace the complete fluid supply at least once per year.

1. Depressurize and disconnect hydraulic hose from ram.
2. With pump in its upright, horizontal position, remove the air vent plug located on the top plate of the reservoir.
3. Use a small funnel to fill reservoir to within 3/4" (19mm) of the opening.
4. Pour used fluid into a sealable container.
5. Dispose of fluid in accordance with local regulations.
6. Fill with a good quality hydraulic oil as recommended above. Reinstall air vent plug.

Lubrication

Use a light machine oil to lubricate pivot points, hinges etc.

When not in use or during storage

- a. Depressurize and hydraulic hose.
- b. Wipe clean, thoroughly.
- c. Store in clean, dry environment. Avoid extreme temperatures.
- d. For transportation or long storage, replace air vent plug (black color) with shipping plug (red color).
- e. Shield pump with a protective cover.

Note: Never operate pump when it is disconnected from ram. If operated in this condition, the hose and connections become pressurized. This increases burst hazard. Damage may occur to pump and its components.

MAINTENANCE (Crane)

Lubrication

A periodic coating of light lubricating oil to pivot points and hinges will help to prevent rust and assure that assemblies move freely.

Cleaning

Periodically check the ram for signs of rust or corrosion. Clean as needed and wipe with an oily cloth. Never use sandpaper or abrasive material on ram plunger surface.

Storage

Store unloaded crane with both leg extensions and boom extension in the **pinned** storage (retracted) position. Store in a clean, dry environment with boom fully lowered and pump depressurized. Depressurize the pump by pressing on the stirrup shaped portion of the pump pedal until the boom is in its lowest position. The hydraulic hose will become less rigid when depressurized.

TROUBLESHOOTING

Symptom	Possible Causes	Corrective Action
Ram will not extend, move or respond to pressurized fluid	<ul style="list-style-type: none"> • Overload condition 	<ul style="list-style-type: none"> • Relieve overload condition
Ram responds to pressurized fluid, but system does not maintain pressure	<ul style="list-style-type: none"> • Overload condition • Ram, pump malfunction 	<ul style="list-style-type: none"> • Relieve overload condition • Contact Service Center
Ram will not return fluid to pump (i.e. cylinder will not retract)	<ul style="list-style-type: none"> • Malfunctioning coupler, damaged ram • Reservoir overfilled 	<ul style="list-style-type: none"> • Secure load by other means. Depressurize pump and hose, remove coupler and/or application, then renew or replace • Secure load by other means. Depressurize pump and hose, remove application, then drain fluid to proper level
Ram will not fully extend	<ul style="list-style-type: none"> • Fluid level low 	<ul style="list-style-type: none"> • Secure load by other means. Depressurize pump and hose, remove application, then ensure proper fluid level
Poor performance	<ul style="list-style-type: none"> • Fluid level low • Ram, pump malfunction 	<ul style="list-style-type: none"> • Ensure proper fluid level • Contact Service Center

Model No. HW93806

Item	Part No.	Description
1	806-002-012	Swivel Caster Assy.
2	806-002-011	Front Wheel
3	806-002-007	Swivel Hook
4	806-002-006	Shackle
5	806-002-024	Boom Axle Retaining Ring (2)
6	806-002-101	Ram Cyclinder
7	22903	Pump
8	CS3838	Hose
9	806-002-022	Retaining Ring (6)
10	806-002-018	Leg Extension Lock Pin (2)
11	806-002-010	Boom Extension Lock Pin
12	CH38	Coupler Set (not shown)
--	HW93806-M0	Owners Manual - Crane
--	22903-M0	Owners Manual - Pump
--	HW93806-L0	Label, Crane
--	22903-L0	Label, Pump

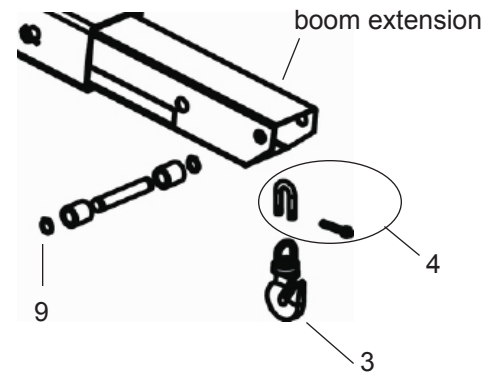

Figure 6- Shackle Assy.

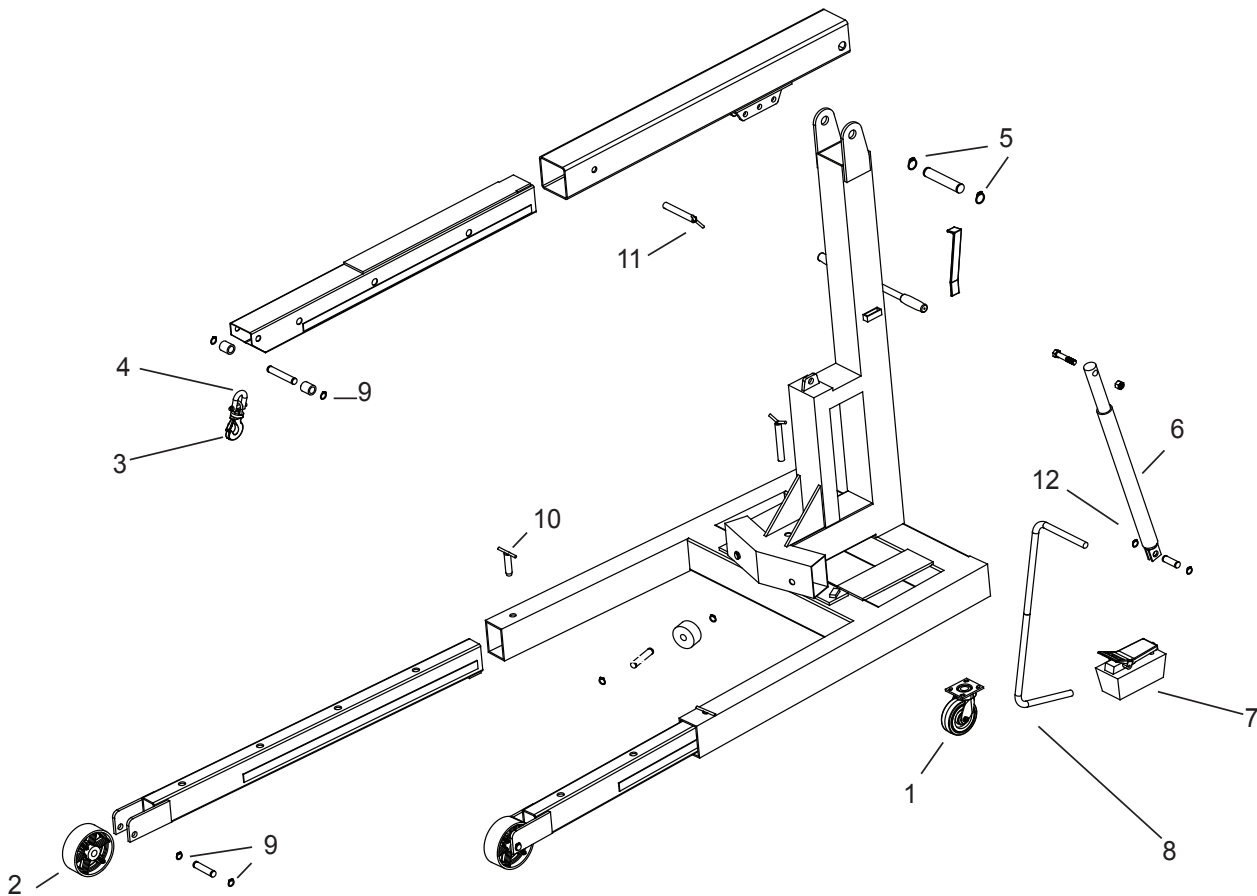

Figure 7: Replacement Parts Illustration for Model HW93806



memo
