



Engine Crane

Operating Instructions & Parts Manual

Model
HW93809

Maximum Rated Capacity
2 Ton

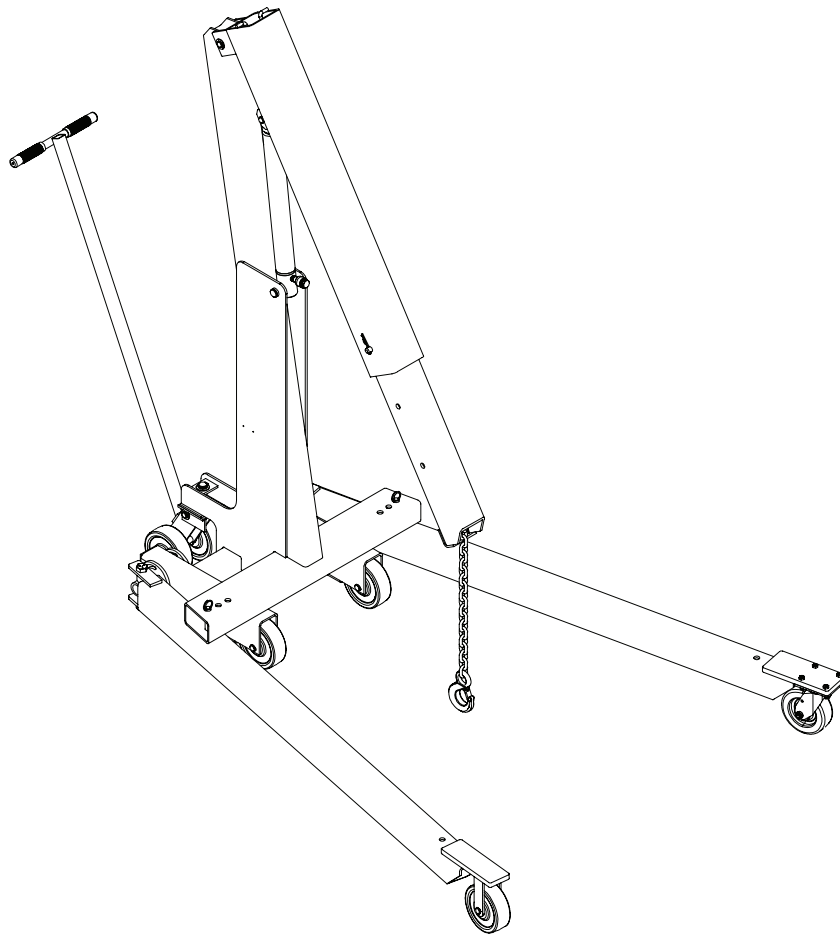

This is the safety alert symbol. It is used to alert you to potential personal injury hazards. Obey all safety messages that follow this symbol to avoid injury or death.

SFA Companies
10939 N. Pomona Ave. Kansas City, MO 64153
customerservices@heinwerner-automotive.com

Read this manual and follow all the Safety Rules and Operating Instructions before using this product

HW93809-M0_072012

TABLE OF CONTENTS

Safety and General Information	2
Product Description & Specifications	2
Assembly/Preparation	3
Operation	8
Maintenance	11
Troubleshooting	12
Warranty	12

SAFETY AND GENERAL INFORMATION

Save these instructions. For your safety, read, understand, and follow the information provided with and on this device before using. The owner and/or operator shall have an understanding of the device, its operating characteristics and safety operating instructions before operating the equipment. The owner and/or operator shall be aware that use and repair of this product may require special skills and knowledge. Instructions and safety information shall be read to and discussed with the operator in the operator's native language, making sure that the operator comprehends their contents, before use of this equipment is authorized. If any doubt exists as to the safe and proper use of this device, remove from service immediately.

Inspect before each use. Do not use if abnormal conditions such as cracked welds, damaged, loose or missing parts are noted. Any equipment that appears damaged in any way, is found to be worn, or operates abnormally shall be removed from service until repaired. If the equipment has been or is suspected to have been subjected to an abnormal load or shock, immediately discontinue use until inspected by a factory authorized repair facility (contact distributor or manufacturer for list of authorized repair facilities). It is recommended that an annual inspection be made by an authorized repair facility. Labels and Operator's Manuals are available from the manufacturer.

SIGNAL WORDS

 DANGER Indicates situation which, if not avoided, will result in death or serious injury	 WARNING Indicates situation which, if not avoided, could result in death or serious injury
 CAUTION Indicates situation which, if not avoided, could result in minor or moderate injury	NOTICE Indicates situation which, if not avoided, could result in damage to property

 WARNING
<ul style="list-style-type: none">• Study, understand and follow all instructions before operating this device.• Do not exceed rated capacity.• Use only on hard, level surface.• Before moving, lower the load to the lowest possible point.• Use only slings or chains with a rated capacity greater than the weight of the load being lifted.• Do not allow load to swing or drop violently while lowering or moving.• No alterations shall be made to this product.• Failure to heed these markings may result in personal injury and/or property damage.

PRODUCT DESCRIPTION

This Hein-Werner 2-Ton Engine Crane is designed to safely lift, lower, and transport in the lowest position, rated capacity engines. HW93809 comes with leg and boom extension sections that can extend, retract, and lock in position.

SPECIFICATIONS

Model	Capacity			Max Boom Height		Overall Boom Height (Horizontal)
	Retracted	Centered	Extended	Retracted	Extended	
HW93809	4400 lbs.	3800 lbs.	3300 lbs.	119"	130"	84"

Boom Reach		Overall Length	Weight
Retracted	Extended		
50-3/4"	35-3/4"	82"	640 lbs.

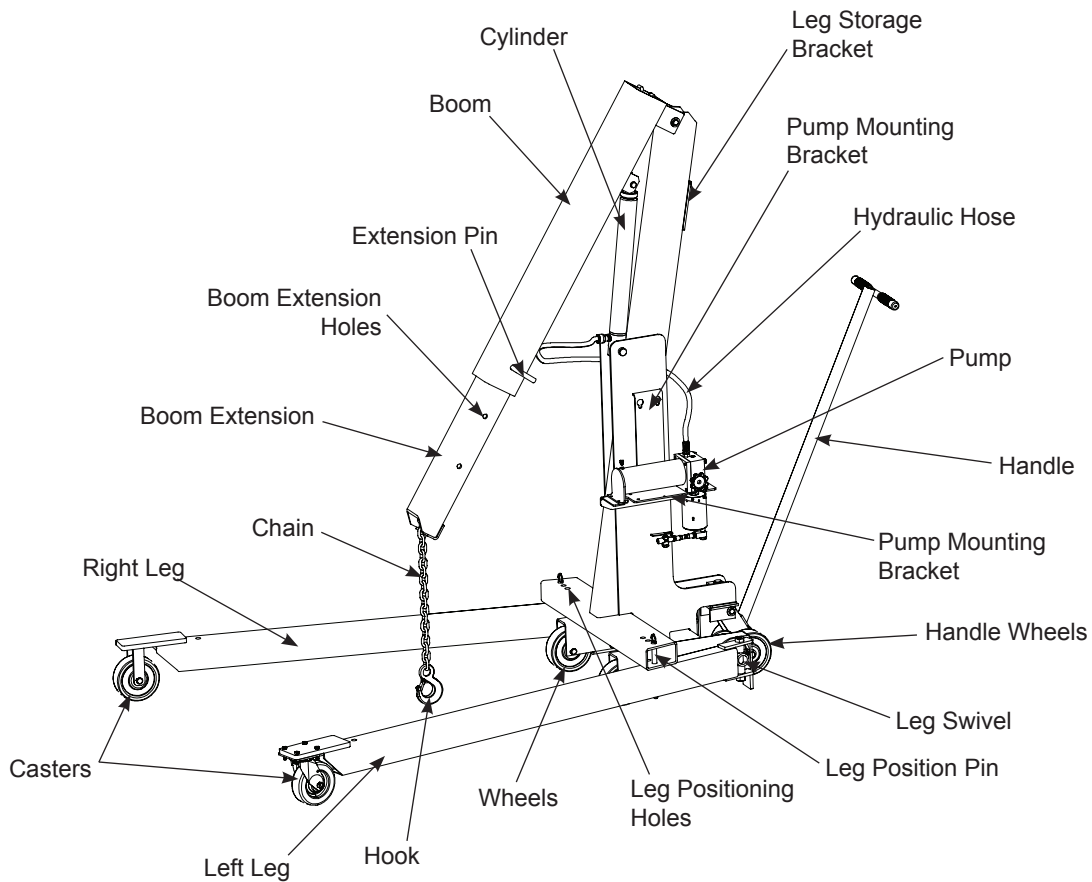

Figure 2: Model HW93809 Components

ASSEMBLY

Hydraulic Pump Installation

The HW93809 is available with either a hand powered pump (MP-100) or an air powered pump (AHP-100). Verify you have the correct pump model before continuing with the installation.

⚠ WARNING: Use of the wrong pump model on the crane can cause the crane to be overloaded resulting in possible damage to the crane and/or sudden dropping of the supported load. ONLY use the pump model provided with your crane or an exact replacement from the crane manufacturer. NEVER use an aftermarket pump on the crane.

ASSEMBLY (cont)

1. Insert the two 3/8" x 3/4" flange head bolts [#1] through the holes in the pump [#4] as shown in Figure 1 and start two 3/8" nuts [#2] onto the bolts. Only start the nuts [#2] one or two turns onto the bolts [#1].
2. On the opposite end of the pump [#4], insert two 3/8" x 1" bolts [#3] and start a 3/8" nut [#2] on each bolt. See Figure 1. Only start the nuts [#2] one or two turns onto the bolts [#3].

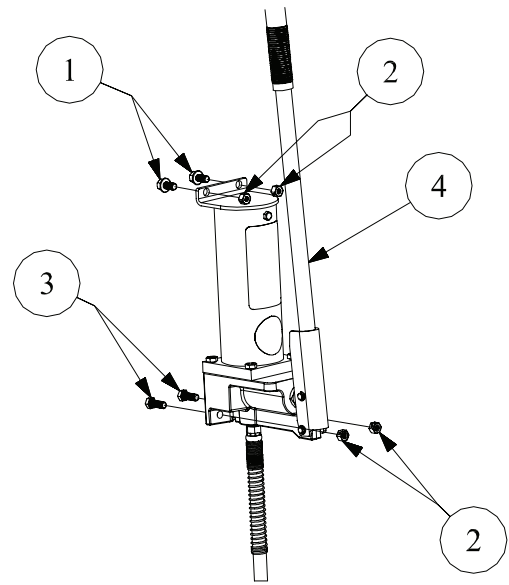

Figure 1

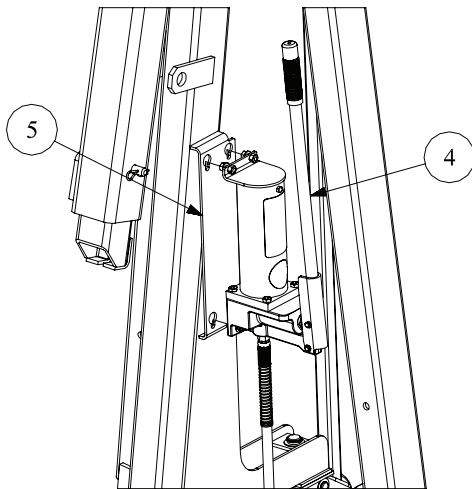

Figure 2

3. Align the pump [#4] with the keyhole slots in the bracket [#5] on the side of the crane as shown in Figure 2.
4. Move the pump [#4] against the bracket [#5] ensuring that the heads of all the bolts pass through the keyhole slots in the bracket [#5].
5. Once the heads of all the bolts [#1 & #3] have passed through the keyhole slots in the bracket [#5] lower the pump [#4] so the bolts [#1 & #3] rest in the bottom of the slots.
6. Tighten all four 3/8" nuts [#2] to secure the pump [#4].

7. Remove the shipping plug [#6] from the pump [#4] as shown in Figure 3.
8. Check the oil level in the pump. The oil level should be 2" to 3" from the bottom of the hole. If the oil level is low, add hydraulic fluid equivalent to Conoco MV22 until the level is 2" to 3" from the bottom of the hole.
9. Install the breather vent plug [#7], provided with the crane, in the pump [#4] in the same hole the shipping plug [#6] was removed from in Step 7.

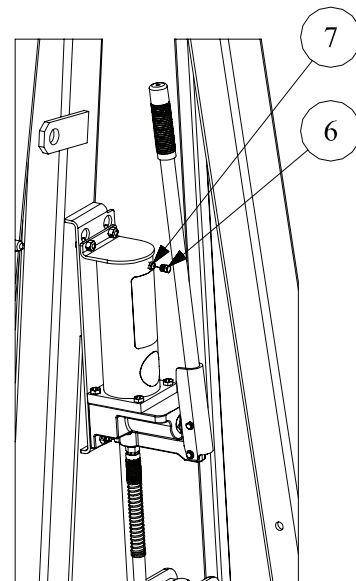

Figure 3

1. Attach the pump bracket [#8] to the bracket [#9] on the side of the crane using two 3/8" x 3/4" flange head bolts [#10] and two 3/8" nuts [#11] as shown in Figure 4. Be sure to attach the pump bracket [#8] to the bottom set of keyhole slots in the bracket [#9].

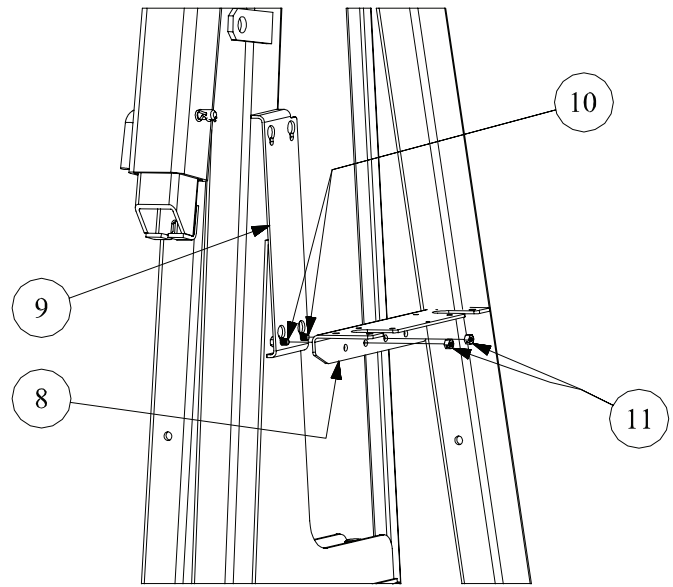

Figure 4

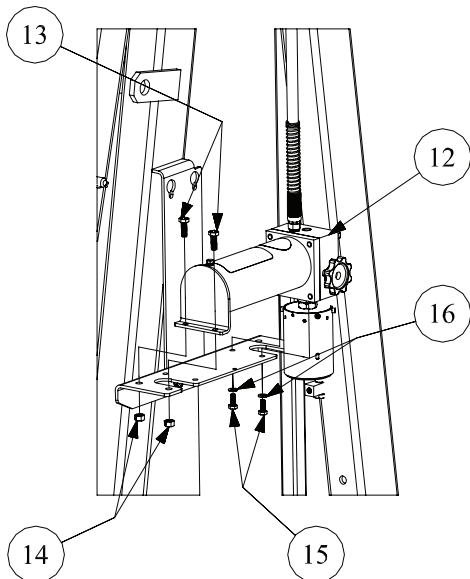

Figure 5

2. Mount the air pump [#12] to the pump bracket [#11] as shown in Figure 5. Use two 3/8" x 1" bolts [#13] and 3/8" nuts [#14] to secure the reservoir end of the air pump [#12]. The opposite end of the air pump [#12] is attached to the pump bracket [#11] using two 5/16" x 3/4" bolts [#15] and two 5/16" lock washers [#16]. The 5/16" x 3/4" bolts [#15] thread into tapped holes in the air pump [#12].

3. Attach the S-hook [#17] to the hole in the pump bracket [#11] as shown in Figure 6.
4. Route the air hose [#18] through the S-hook [#17]. The S-hook [#17] can be closed around the air hose [#18], if desired. Be careful to not pinch or cut the air hose [#18] when closing the S-hook [#17]. Otherwise, the S-hook [#17] can be left open so the air hose [#18] can be inserted or removed from the hook as desired. The purpose of the S-hook [#17] is to provide a location to hang the air hose [#18] that prevents it from dragging on the floor.

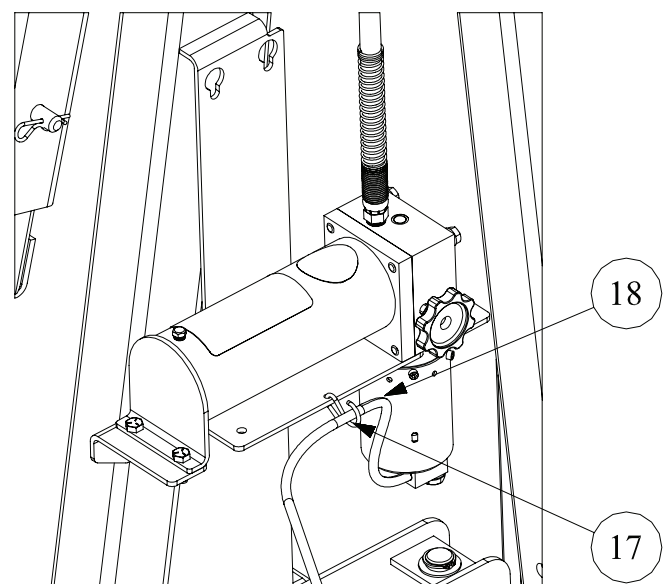

Figure 6

ASSEMBLY (cont)

5. Remove the shipping plug [#19] from the pump [#12] as shown in Figure 7.
6. Check the oil level in the pump. The oil should be 1" to 1-1/4" from the bottom of the hole. If the oil level is low, add hydraulic fluid equivalent to Conoco MV22 until the level is 1" to 1-1/4" from the bottom of the hole.
7. Install the breather vent plug [#20], provided with the crane, in the pump [#12] in the same hole the shipping plug [#19] was removed from in Step 5.

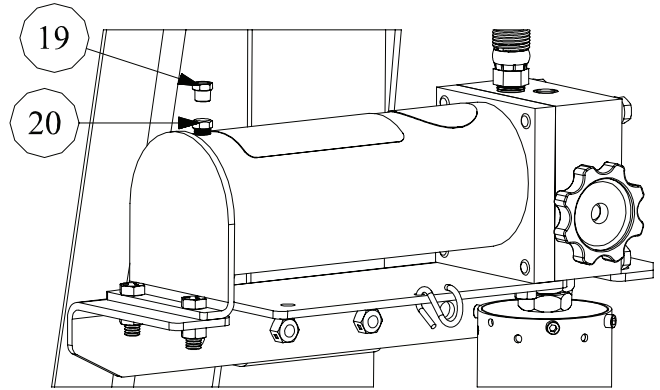

Figure 7

Hydraulic Cylinder Installation

Any air in the cylinder [#21] must be removed from the cylinder for proper functioning of the crane.

1. Remove the protective cap and seal from the quick coupler [#22] on the cylinder [#21].
2. Connect the hydraulic hose [#23] to the quick coupler [#22] on the cylinder [#21] by inserting the male end of the hose [#23] into the quick coupler [#22] and thread the quick coupler's collar onto the hose.
3. Support the cylinder [#21] so the end with the quick coupler [#22] is higher than the rod end. Route the hose [#23] from the cylinder [#21] back to the pump so the hose [#23] is lower at the end that connects to the cylinder [#21] than at the end that connects to the pump.
4. SLOWLY extend the cylinder rod from the cylinder [#21] by closing the release knob and actuating the pump until the cylinder rod is fully extended. After the cylinder rod has been extended, open the release knob and hold the cylinder so that the quick coupler fitting is on the upper part of the cylinder and the cylinder rod is pointing down. Carefully push the rod into the cylinder until it is fully retracted. Repeat this process to ensure there is as little air as possible left in the cylinder.

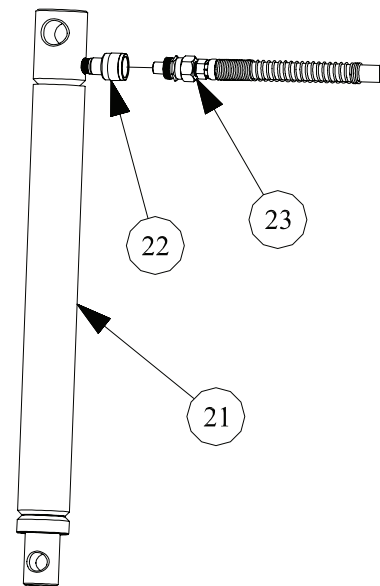

Figure 8

⚠ WARNING: Any operation of the cylinder while detached from the crane must be done carefully. If the cylinder is extended too quickly or is pressurized to much it poses the possibility of hitting someone, moving unexpectedly, or breaking apart and may lead to property damage, serious personal injury, and/or death.

5. Disconnect the hydraulic hose [#23] from the quick coupler [#22] once all the air has been purged from the cylinder.

- Mount the rod end of the hydraulic cylinder [#21] to the cylinder mounting bracket [#24] located on the boom by aligning the cylinder's hole with the holes in the mounting bracket and insert the 3/4" upper cylinder retaining pin [#25] as shown in Figure 9.
- Place a 3/4" washer [#26] onto the retaining pin [#25] and then snap a 3/4" retaining ring [#27] into the groove on the retaining pin [#25] and push the retaining pin [#25] until the retaining ring [#27] stops its travel.

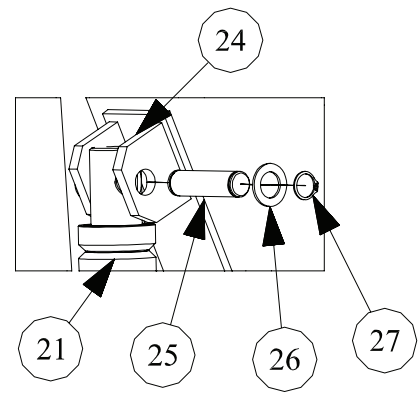

Figure 9

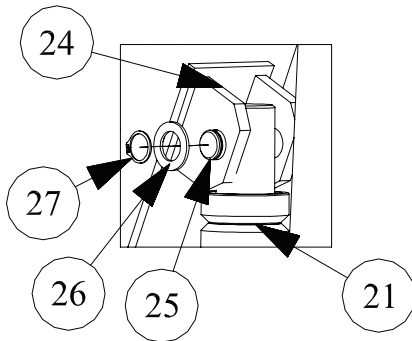

Figure 10

- On the opposite side of the retaining pin [#25], place the other 3/4" washer [#26] onto the retaining pin [#25] and then snap the other 3/4" retaining ring [#27] into the groove on the retaining pin [#25] as shown in Figure 10.

- Align the hole on the quick coupler end of the cylinder [#21] with the holes of the cylinder mounting plates [#28], lifting the boom if necessary and making sure that the hydraulic hose quick coupler fitting is pointing away from the frame of the crane as shown in Figure 11. Insert the 1" lower cylinder retaining pin [#29] into the aligned holes and adjust so that an approximately equal length protrudes from each of the mounting plates. Place a 1" washer [#30] onto each side of the retaining pin and snap a 1" retaining ring [#31] into each of the grooves in the retaining pin.

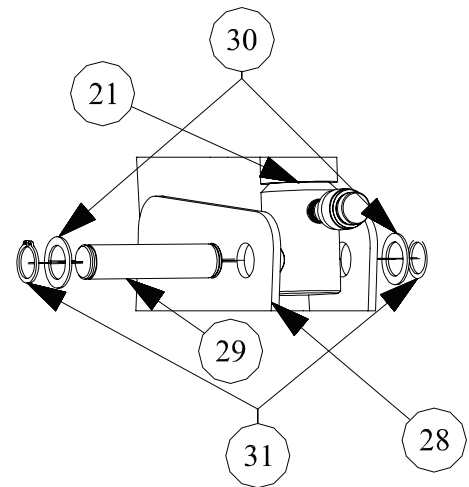

Figure 11

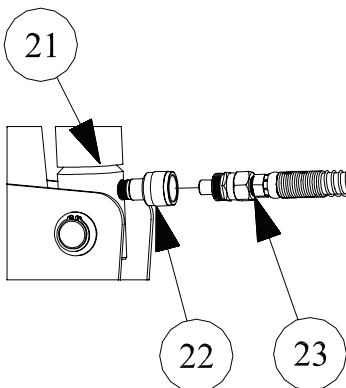

Figure 12

- Insert the hydraulic hose [#23] into the cylinder's quick coupler [#22] and thread the quick coupler's collar onto the hose.

OPERATION

NOTICE: It may be necessary for some or all of the following steps to be completed using two people.

⚠ WARNING: Using this crane requires several steps which must be followed each and every time the crane is used:

1. Adjusting the boom
2. Adjusting the legs
3. Positioning the crane
4. Securing the load
5. Adjusting the load height
6. Moving the load
7. Folding the legs for storage

Each of these steps is discussed in detail in the following sections. Failure to follow all of these instructions can lead to serious injury and/or death.

Adjusting the Boom

1. To adjust the boom's extension length between the crane's three boom positions, the extension pin must first be removed from the boom.
2. After the extension pin is removed, slide the boom extension in or out of the boom until the desired position is reached.
3. The extension pin must then be inserted into the boom extension holes that are in line with the boom's pin holes before the crane is operated further. The capacity of the crane in each of the extension positions must be noted prior to attaching a load and that capacity must not be exceeded.

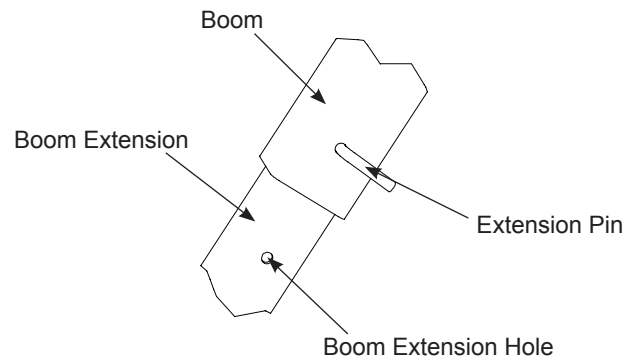

Figure 13

⚠ WARNING: The crane's extension pin must be in place before operating the crane and the capacity for that extension position must not be exceeded. Operating the crane without the extension pin or with a load that exceeds capacity may result in equipment failure leading to property damage, serious personal injury, and/or death.

Adjusting the Legs

1. If not already lowered, the crane's legs must both be lowered so the casters rest on the floor prior to using the crane to lift a load.

⚠ WARNING: Lifting a load with the crane while either of the legs is in the folded position could cause instability of the crane. The crane may tip or fall over causing property damage, serious personal injury, and/or death.

2. To adjust the spread of the crane's legs, the leg positioning pin must be removed from each leg that is to be repositioned.
3. Each leg can then be swiveled into the desired position of the three possible positions. The leg positioning pin from each repositioned leg must then be inserted into the leg positioning holes and through that leg's pin holes.

⚠ WARNING: Failure to properly insert the leg positioning pin into each leg can cause instability in the crane and may lead to property damage, serious personal injury, and/or death.

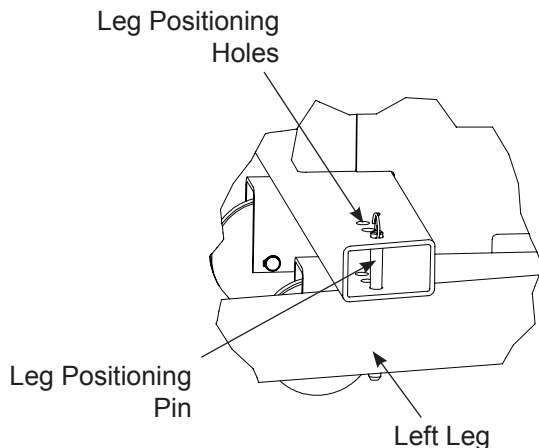

Figure 14

Positioning the Crane

After the crane has been properly adjusted, it can be moved in to position to secure the intended load. The crane must be able to freely roll into position and all potential obstacles must be carefully negotiated or moved. When positioning the crane, always consider the way in which the load will be secured to the crane. The crane's chain, or other adequate load capturing device that meets or exceeds the capacity of the crane in its given position, must be located directly over the intended load before attempting to secure the load. It is important to the safety of the crane operator and other personnel that the path of the crane is carefully planned, both before and after securing the load.

⚠ WARNING: *Contacting any obstacle, including overhead obstacles, with the crane can make the crane jump or shift which can cause the load to swing or rotate dangerously and may lead to property damage, serious personal injury, and/or death.*

Securing the Load

Once the shop crane has been positioned, the load must be secured utilizing an adequate capturing device, such as a load leveler, chain, or sling, capable of sustaining the load. The load must be secured by using attachment points that are adequate for holding the weight of the load and allow the load to be lifted without shifting or rotating. Ensure that the hook and chain assembly or other adequate load capturing device is directly above the load to be raised. Pay careful attention to how the load will react when raised. If the center of gravity of the load is not directly under the crane's capturing device, or the load is awkwardly captured, the load and crane may swing or rotate dangerously.

⚠ WARNING: *Ensure that the load is properly secured before attempting to lift or move it. If the load is improperly secured it can unexpectedly fall, swing, or rotate dangerously which may lead to property damage, serious personal injury, and/or death.*

Adjusting the Load Height

The hydraulic pump is used to adjust the height of the load.

1. To raise the load, the release knob on the pump must be closed by turning the knob clockwise until it is finger tight.
2. The pump can then be actuated by working the handle on the manual pump or activating the air valve on the air hydraulic pump, depending on which type of pump is installed.
3. While the pump is actuated, the cylinder will extend raising the boom and load.
4. To lower the load, the release knob must be opened by SLOWLY turning the knob counter-clockwise. This will lead to retraction of the cylinder and lowering of the load.
5. Once the load is at the desired height, the release knob must be closed in order to keep the load at that height.

⚠ WARNING: *Lowering or stopping the load too quickly can cause the load to swing or rotate dangerously and may result in property damage, serious personal injury, and/or death. This crane is not intended for overhead lifting. Do not allow the crane's load or boom to be above any body part. If the load were to fall, it would cause serious personal injury or death.*

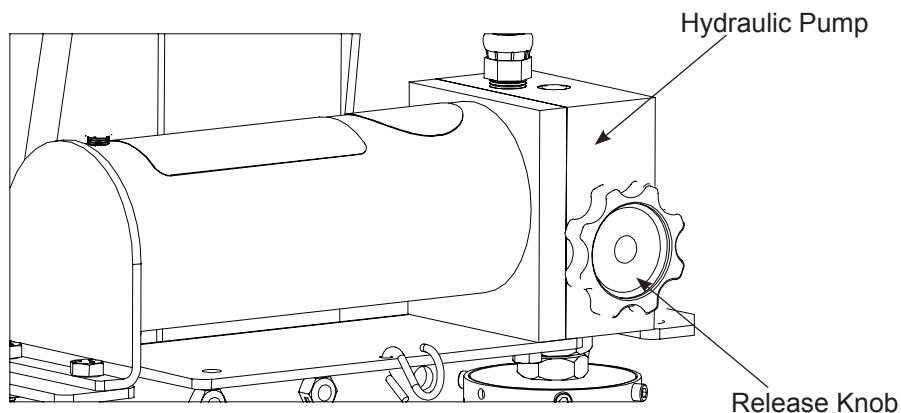

Figure 15

Moving the Load

Before and while SLOWLY moving the crane, pay close attention to the crane's immediate surroundings. Ensure that all obstacles are moved from the crane's path and do not neglect to consider the boom's overhead path as well as the path that the legs will follow on the floor. Before moving the crane and load, position the load at its lowest possible height. Once any height restricting obstacles (i.e. engine compartment) have been cleared by the load, stop and reposition the load to its then current lowest possible height and continue doing so until all obstacles have been cleared. After the load has been successfully moved to the desired location, it should be lowered on to or attached to a surface or device (i.e. engine stand) that will adequately support the load.

⚠ WARNING: *The crane is designed for lifting, moving, and lowering a load and is not intended to hold or support a load for extended periods of time. Moving or stopping the crane too quickly or recklessly can cause the load to swing or rotate dangerously and may result in property damage, serious personal injury, and/or death.*

After the load is removed from the crane, the crane's legs can be folded up for storage.

1. Remove the leg positioning pin from each of the crane's legs.
2. Rotate the legs outward until they clear the crane's frame.
3. Separately lift each of the legs and rotate them until they are vertical. Insert the leg positioning pin into the leg and then through the leg storage bracket as shown in Figure 16. Ensure that the pin has secured the leg onto the leg storage bracket and that the leg positioning pin is fully inserted into the leg.

⚠ WARNING: *Failing to properly secure the legs can cause the legs to fall unexpectedly and may result in property damage, serious personal injury, and/or death.*

Folding the Legs for Storage

After the load is removed from the crane, the crane's legs can be folded up for storage.

1. Remove the leg positioning pin from each of the crane's legs.
2. Rotate the legs outward until they clear the crane's frame.
3. Separately lift each of the legs and rotate them until they are vertical. Insert the leg positioning pin into the leg and then through the leg storage bracket as shown in Figure 16. Ensure that the pin has secured the leg onto the leg storage bracket and that the leg positioning pin is fully inserted into the leg.

⚠ WARNING: *Failing to properly secure the legs can cause the legs to fall unexpectedly and may result in property damage, serious personal injury, and/or death.*

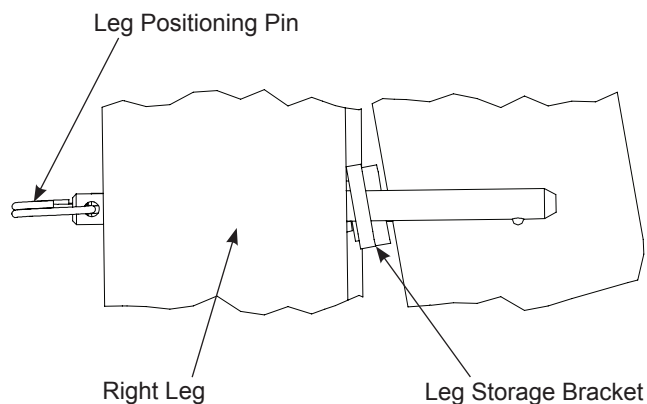

Figure 16

MAINTENANCE

⚠ WARNING: *All inspection and maintenance procedures must be performed after the equipment has been removed from service. Failure to heed this warning may result in personal injury and / or property damage.*

1. Lightly oil all pins to prevent corrosion. The pins that must be oiled are the leg positioning pins, boom extension pin, and the cylinder retaining pins.
2. Lightly oil the chain, hook, and any appropriate part of other load capturing devices to prevent corrosion.
3. If equipped with the AHP-100 air pump, add a few drops of air tool oil to the air line and operate the pump. This will help lubricate the air piston and prevent moisture in the air line from corroding the inside of the air motor.
4. Inspect the condition of all decals on the crane. They should be legible and easy to read. If they become hard to read, clean with a mild soap and water solution or replace immediately.

Structural Inspection

⚠ WARNING: *Equipment must be removed from service and inspected for damage immediately if subjected to an abnormal shock or load. Failure to heed this warning may result in personal injury and / or property damage.*

⚠ WARNING: *The owner must inspect, or appoint a knowledgeable person to inspect the crane for signs of damage, corrosion, excessive wear, oil leaks, air leaks (if equipped with AHP-100 air pump), abnormal operation, or any other potential problem. NEVER use a crane that appears to be damaged in any way. If any irregularities or problems are detected during an inspection, the crane must be removed from service immediately and repaired. Contact customer service at the address and numbers shown on the back cover of this manual to report any problems.*

Use the following procedures to inspect the crane for wear or damage:

Inspect Crane Frame, Chain, and Hook

1. Check the crane for corrosion, cracked welds, or any other damage such as cracks, chips, dents, marring, or other deformation. If any corrosion or damage is discovered, immediately remove the crane from service and contact customer service using the contact information found on the back cover of this manual.
2. Check the crane's chain and hook or other load capturing device for corrosion or any damage such as cracks, chips, dents, marring, or other deformation. Keep all load capturing devices of the crane in good working order. If they are damaged or are excessively corroded, replace. Use only devices supplied by the manufacturer of the crane.

Inspect All Hydraulic Components

1. Inspect the hydraulic hose and fittings for any signs of wear, damage, or oil leaks. NEVER use a damaged hose or fittings.

⚠ WARNING: *Do not bend the hydraulic hose through less than a 5 inch radius.*

⚠ DANGER: *Keep the hydraulic system away from flames and heat. NEVER impact the hydraulic system in any way.*

2. Make sure the release knob operates properly.
3. Inspect the cylinder and cylinder rod for any signs of wear, damage, or oil leaks. The cylinder rod should be straight without any gouges, scratches, or marks. The cylinder must be free of dents, gouges, or other damage. NEVER use a cylinder that is damaged in any way.

Inspect All Air Components (If equipped with AHP-100 only)

⚠ WARNING: *This press is designed to operate with air pressure of 95 psi to 200 psi. Do not exceed this rating.*

1. Check the air line and fittings for signs of wear, damage, or leaks. Replace the air line if any damage is found.
2. Make sure that the air valve is working properly. To prevent the risk of serious injury, the boom must stop immediately when the air valve is released.

Maintenance (cont)

Inspect Boom Extension Pin and Leg Positioning Pins

Inspect the boom extension pin and leg positioning pins for any signs of damage. The pins must not be bent, cracked, corroded, or excessively worn.

⚠ WARNING: NEVER use pins that show any sign of damage. Using damaged pins can cause the pins to fail resulting in a sudden drop of the load and/or instability of the crane causing personal injury and/or property damage.

If the crane is overloaded, take the crane out of service immediately and inspect. Replace any damaged components by contacting customer service at the numbers and address shown on the back cover of this manual. ONLY use repair parts supplied by the manufacturer to repair this crane. NEVER use spare parts from other sources; they may not be designed to be used on this crane or rated at the same capacity.

TROUBLESHOOTING

Symptom	Possible Cause	Corrective Action
Cylinder will not extend	Oil level low	Check oil level. If necessary, add high grade hydraulic fluid equivalent to Conoco MV22 Super Hydraulic Oil. Refer to "Hydraulic Pump Installation" instructions for adding oil.
Cylinder rod does not extend/retract smoothly	Trapped air in hydraulic cylinder	Follow "Hydraulic Cylinder Installation" instructions for purging air from cylinder. Cylinder must be removed from crane, purged and reinstalled as described to properly remove air.
Air motor does not run	<ul style="list-style-type: none">• Air line leaks• Air piston malfunction• Inadequate air pressure	<ul style="list-style-type: none">• Locate and correct leaks.• Add oil to air inlet to lubricate piston.• Air motor requires minimum 95 psi to generate rated load.

TWO YEARS LIMITED WARRANTY

For a period of two (2) years from date of purchase, SFA Companies will repair or replace, at its option, without charge, any of its products which fails due to a defect in material or workmanship under normal usage. This limited warranty is a consumer's exclusive remedy.

Performance of any obligation under this warranty may be obtained by returning the warranted product, freight prepaid, to SFA Companies Warranty Service Department, 10939 N. Pomona Ave., Kansas City, MO 64153.

Except where such limitations and exclusions are specifically prohibited by applicable law:

(1) THE CONSUMER'S SOLE AND EXCLUSIVE REMEDY SHALL BE THE REPAIR OR REPLACEMENT OF DEFECTIVE PRODUCTS AS DESCRIBED ABOVE

(2) SFA COMPANIES SHALL NOT BE LIABLE FOR ANY CONSEQUENTIAL OR INCIDENTAL DAMAGE OR LOSS WHATSOEVER.

(3) ANY IMPLIED WARRANTIES, INCLUDING WITHOUT LIMITATION THE IMPLIED WARRANTIES OF MERCHANTABILITY AND FITNESS FOR A PARTICULAR PURPOSE, SHALL BE LIMITED TO TWO YEARS, OTHERWISE THE REPAIR, REPLACEMENT OR REFUND AS PROVIDED UNDER THIS EXPRESS LIMITED WARRANTY IS THE EXCLUSIVE REMEDY OF THE CONSUMER, AND IS PROVIDED IN LIEU OF ALL OTHER WARRANTIES, EXPRESS OR IMPLIED.

(4) ANY MODIFICATION, ALTERATION, ABUSE, UNAUTHORIZED SERVICE OR ORNAMENTAL DESIGN VOIDS THIS WARRANTY AND IS NOT COVERED BY THIS WARRANTY.

Some states do not allow limitations on how long an implied warranty lasts, so the above limitation may not apply to you. Some states do not allow the exclusion or limitation of incidental or consequential damages, so the above limitation or exclusion may not apply to you. This warranty gives you specific legal rights, and you may also have other rights which vary from state to state.



SFA Companies
10939 N. Pomona Ave. Kansas City, MO 64153
816-891-6390
customerservices@heinwerner-automotive.com

REPLACEMENT PARTS

Not all components of the jack are replacement items, but are illustrated as a convenient reference of location and position in the assembly sequence. When ordering parts, give model number, part number and parts description. Call or write for current pricing: Hein-Werner Customer Support, 10939 N. Pomona Ave. Kansas City, MO 64153. Phone: (816) 891-6390; e-mail: customerservices@heinwerner-automotive.com

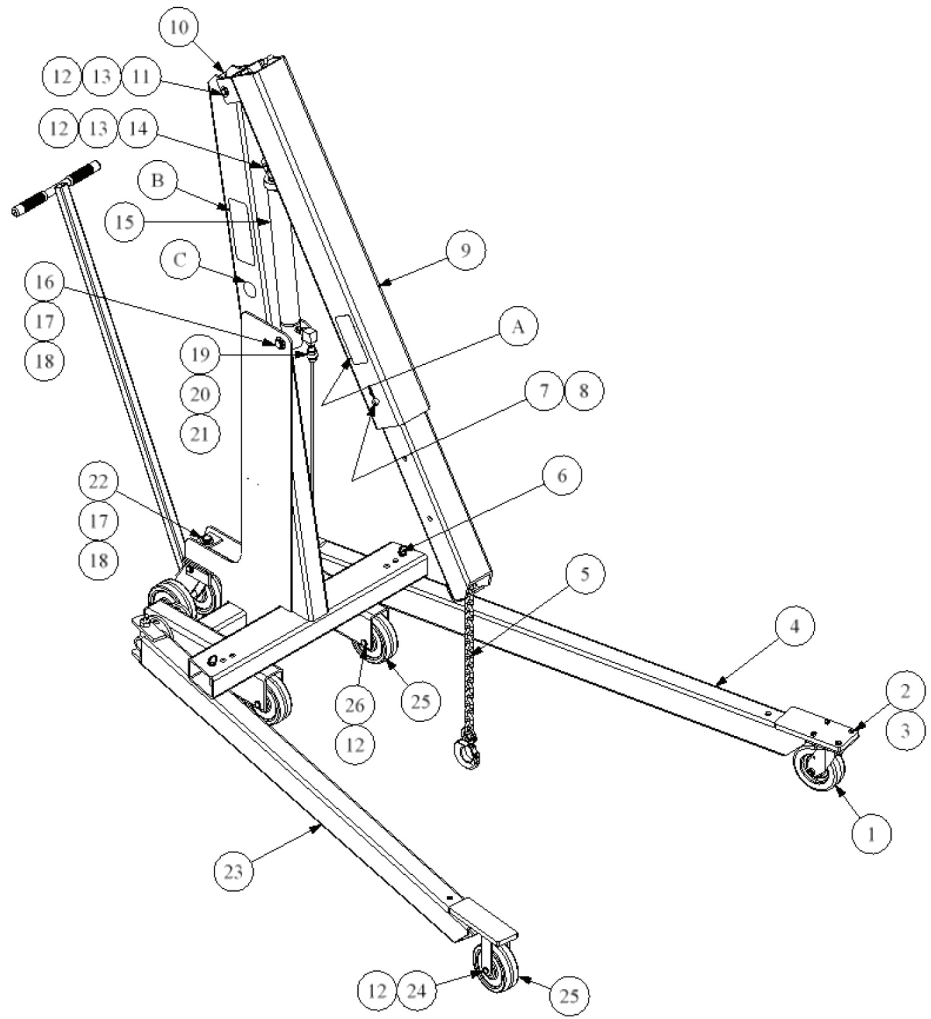

Item	Part Number	Description	Qty
1	480-11040	Caster, Swivel, Plate	1
2	200-31208	Capscrew, Hex Head, 3/8-16 UNC	4
3	203-01206	Nut, Hex, 3/8-16 UNC	4
4	817-02009	Leg Weldment	1
5	234-39020	Chain with Safety Hook	1
6	232-10017	Quick Release Pin	2
7	817-04028	Lock Pin, Boom	1
8	235-00007	Cotter Pin, Hair Type	1
9	817-02007	Boom Stop Weldment	1
10	817-02008	Base Weldment	1
11	817-04048	Boom Pivot Pin	1
12	230-12001	Retaining Ring, External	14
13	204-01707	Washer, Plain	8
14	817-04030	Cylinder Rod Pin	1
15	353-40107	Crane Hydraulic Cylinder	1
16	817-04031	Cylinder Pin	1
17	204-01902	Washer, Flat	3
18	230-13004	Retaining Ring, External	3
19	274-14010	Quick Disconnect Coupler	1
20	275-12001	Elbow, 3/8" NPT	1
21	275-02004	Nipple, Hex, 3/8" NPT	1
22	817-02006	Rear Swivel Caster Yoke Weldment	1
23	817-02010	Leg Weldment	1
24	817-04033	Axle	1
25	480-01018	Wheel, 6" dia.	5

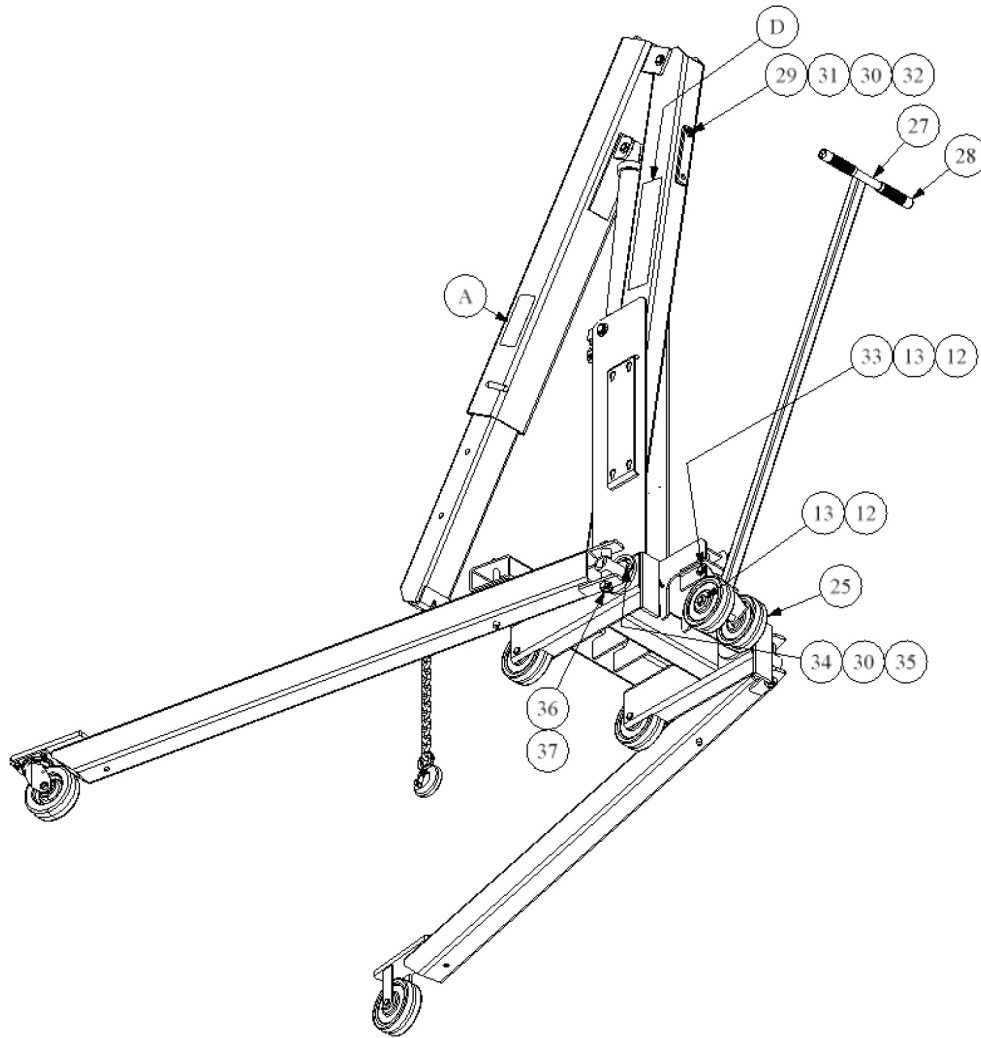

Item	Part Number	Description	Qty
26	817-04032	Axle	2
27	817-02003	Tow Handle Weldment	1
28	232-20114	Hand Grip	2
29	200-31206	Capscrew, Hex Head	1
30	204-01200	Washer, Flat	5
31	082-50026	Tubing, Round	1
32	817-04047	Link, 4400 lb.	2
33	470-23023	Shaft, 3/4" dia.	1
34	201-01220	Capscrew, Socket Head	2
35	203-01202	Nut, Hex, 3/8-16 UNC	2
36	200-31721	Capscrew, Hex Head, 3/8-16 UNC	2
37	203-01705	Nut, Hex, 3/4-10 UNC	2



SFA Companies
 10939 N. Pomona Ave. Kansas City, MO 64153
 816-891-6390
 customerservices@heinwerner-automotive.com