



Air Operated End Lift

Operating Instructions & Parts Manual

Model Number
HW93690

Capacity
10 Ton

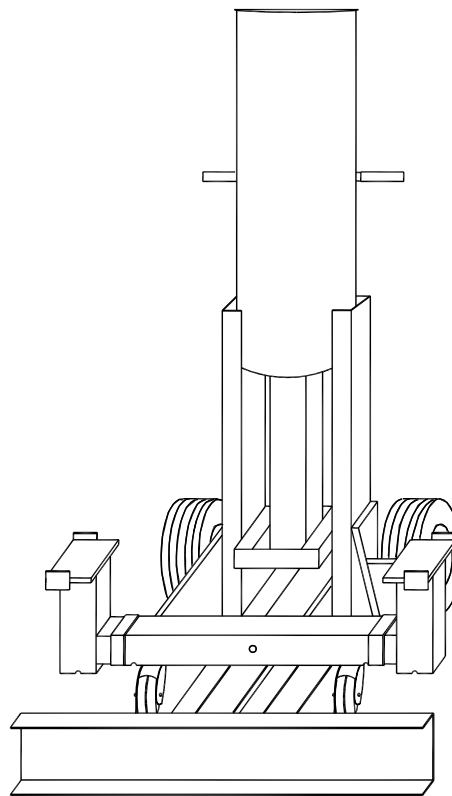

This is the safety alert symbol. It is used to alert you to potential personal injury hazards. Obey all safety messages that follow this symbol to avoid possible injury or death.

SFA Companies
10939 N. Pomona Ave. Kansas City, MO 64153
816-891-6390 customerservices@heinwerner-automotive.com

Read this manual and follow all the Safety Rules and Operating Instructions before using this product.

SAFETY and GENERAL INFORMATION

Save these instructions. For your safety *read, understand, and follow* the information provided with and on this lift. The owner and operator of this equipment shall have an understanding of this lift and safe operating procedures before attempting to use. The owner and operator shall be aware that use and repair of this product may require special skills and knowledge. Instructions and safety information shall be conveyed in the operator's native language before use of this lift is authorized. If any doubt exists as to the safe and proper use of this lift, remove from service immediately.

Inspect before each use. Do not use if broken, bent, cracked, or damaged parts (including labels) are noted. Any lift that appears damaged in any way, operates abnormally or is missing parts, shall be removed from service immediately and the manufacturer notified. If you suspect that the lift was subjected to a shock load (a load dropped suddenly, unexpectedly upon it), immediately discontinue use until the lift has been checked by a factory authorized service center (contact distributor or manufacturer for list of Authorized Service Centers). It is recommended that an annual inspection be done by qualified personnel. Replace worn or damaged parts with Hein-Werner Authorized Replacement Parts only. Labels and owner's manuals are available from manufacturer.

PRODUCT DESCRIPTION

Hein-Werner Air Operated End Lift is designed to lift, but not support rated capacity loads. **Intended use:** To engage the metal bumper of a vehicle and raise for the purpose of service and/or repair of vehicle components. Immediately after lifting, the load must be supported by a pair of appropriately rated jack stands.



Never use lift as a stand alone device. After lifting, immediately support the lifted load with a pair of appropriately rated jack stands.

SPECIFICATIONS

Model	Capacity	Min. Height	Max. Height	Power Travel	Saddle Spread	Min. Air Pressure for Rated Load	Weight
HW93690	10 Ton	12 1/2"	50 1/2"	28"	25" to 53"	200 psi	670 lb.

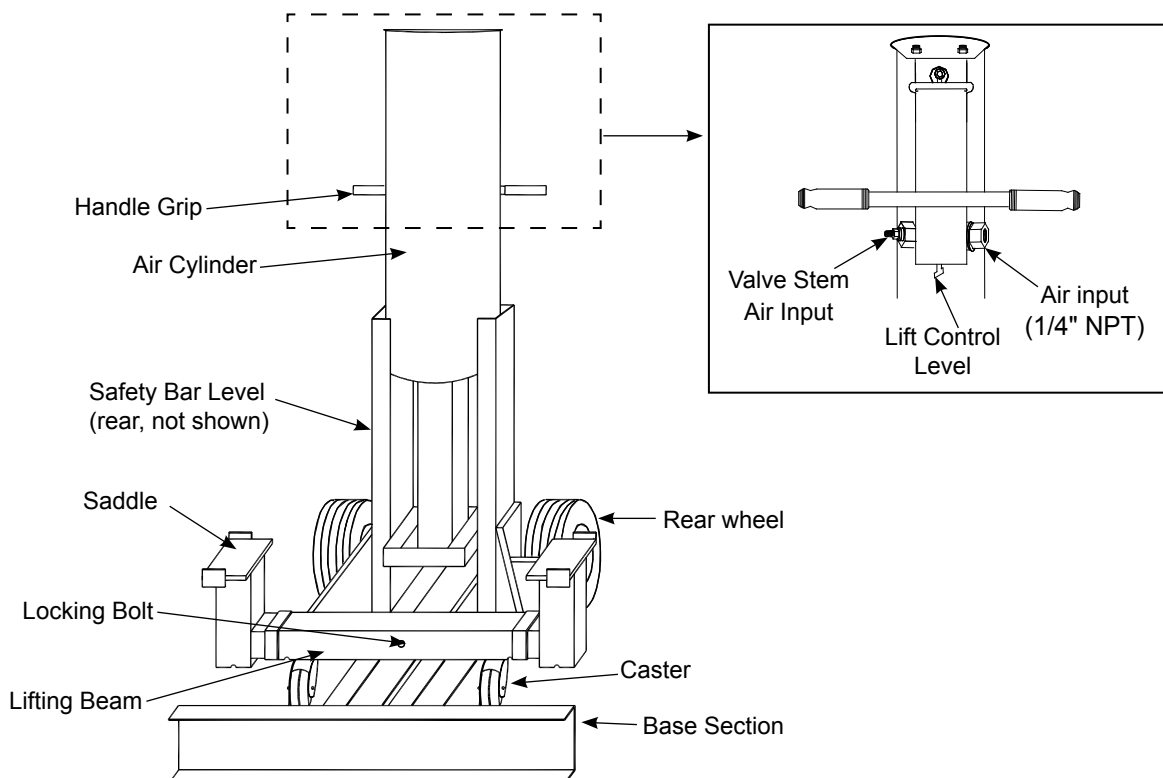
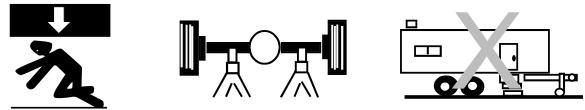

Figure 1 - Model HW93690 Components

WARNING

- **Study, understand, and follow** all printed materials provided with/on this product before use.
- **Do not** exceed rated capacity.
- Use only on hard, level surface.
- **This is a lifting device only!**
- **Immediately** after lifting, support the load with **a pair** of appropriately rated jack stands.
- Center load on saddle.
- Do not use adapters or accessories that are not provided initially.
- Never lift vehicle which cannot roll freely forward and backward during lift.
- Lift only on areas of the vehicle as specified by the vehicle manufacturer.
- Do not move or dolly loads with this device.
- No alterations shall be made to this product.
- Failure to heed these markings may result in personal injury and/or property damage.

WARNING



To avoid **crushing and related injuries**:

- **Never** work on, under or around a load supported only by the end lift.
- **Always** use adequately rated jack stands.
- **Do not** use this device to lift, level, lower, support nor move a house, mobile home, travel trailer, camper or any building structure.
- **Be alert** and **sober** when using this product. Do not operate under the influence of drugs or alcohol.

ADVERTENCIA

- Leer, comprender, y seguir las instrucciones antes de utilizar el aparato.
- El manual de instrucciones y la información de seguridad deben estar comunicado en lengua del operador antes del uso.
- No seguir estas indicaciones puede causar daños personales o materiales.

PREPARATION

Before Use

1. Verify that the product and application are compatible, if in doubt call Hein-Werner technical service.
2. Before use, read the operator's manual completely and familiarize yourself thoroughly with the product, its components and recognize the potential hazards associated with its use.
3. Ensure that lift rolls freely, the air cylinder operates smoothly, raises and lowers the unloaded saddle throughout the lifting range before putting into service.
4. Ensure the lift is loaded on center with the saddles placed equal distance from the center.
5. Replace worn or damaged parts and assemblies with Hein-Werner Replacement Parts only. Lubricate as instructed in Maintenance Section.

Prepare air system

Connect 1/4" NPT quick coupler of your choice to the air input (Fig. 1).

Note: Air source must supply 200 psi maximum to each lift operated.

OPERATION



Only attachments and/or adapters supplied by the manufacturer shall be used. Lift only on areas of the vehicle as specified by the vehicle manufacturer.



NEVER use lift as a stand alone device! **ALWAYS** transfer the lifted load **IMMEDIATELY** to a pair of appropriately rated jack stands. Use one pair of jack stands per vehicle. Rated capacity is per pair only! Do not exceed rated capacity.

Lifting

1. Ensure that the vehicle is on a flat, hard and level surface and is free to roll forward and backward during the lift.
2. Connect 1/4" NPT air nipple and air hose to air inlet port.
3. To adjust the length of the lifting beams, pull both beam extensions out evenly to suitable length.



NEVER extend beam extensions beyond locked position. Retaining bar of the beam extensions must be secured together with the locking bolt.

4. Adjust the saddle height by pulling saddle tube up, then insert the support pin through the hole on saddle tube.
5. For low pickup height, unscrew the locking bolt and nut, then rotate the beam extensions 180 degrees. Refer to Figure 2.

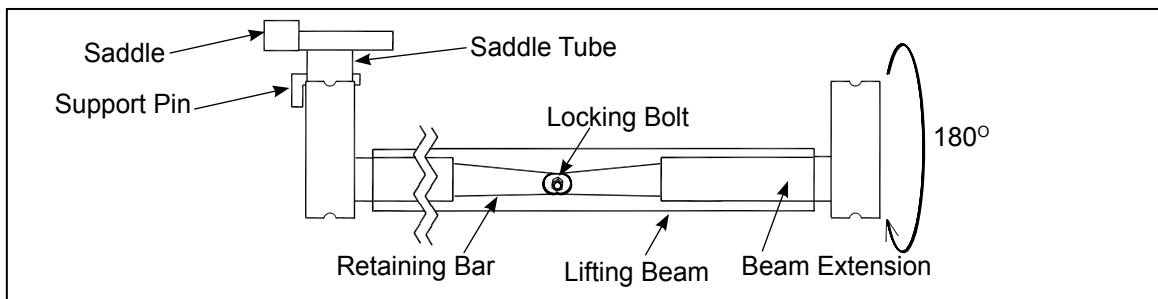

Figure 2.

6. Make sure both saddles are positioned directly under the vehicle manufacturer's recommended lift points.
7. To raise lift, slowly push the lift control lever toward the right until saddles contact with the lift point.
!STOP! RELEASE THE LIFT CONTROL LEVEL! Confirm that the saddles are positioned correctly, then continue to push the lever until load reaches desired height. Simply release the lever to stop.
8. Transfer the load immediately to appropriately rated jack stands.

Lowering



Be sure all tools and personnel are clear before lowering load. **Maintain control** of the rate of speed at which the load lowers at all times!

1. Raise load high enough to clear the jack stands, then carefully remove jack stands (**always** used in pairs).
2. Slowly lower the load by disengaging safety bar* and push lift control lever toward the left.

* **To disengage safety bar:** Push safety bar lever towards front end of the lift.

MAINTENANCE

Lubricate all moving parts with oil/grease.

Lubrication

A periodic coating of light lubricating oil to pivot points, axles and hinges will help to prevent rust and assure that wheels, and caster assemblies move freely.

Storage

When not in use, store the lift with cylinder fully lowered.

TROUBLESHOOTING

Symptom	Possible Causes	Corrective Action
The lift will not lift load	<ul style="list-style-type: none">• Air pressure too low• Air hose kinked or plugged• Air hose inner diameter too small• Air cylinder / components damaged	<ul style="list-style-type: none">• 200 psi minimum air pressure required to lift rated load• Remove kinks and obstruction from air hose• Consult air compressor manufacturer for the correct size of hose• Contact Hein-Werner repair center
Lift will not lower after unloading	<ul style="list-style-type: none">• Safety bar engaged• Structural damage to lift assembly	<ul style="list-style-type: none">• Press lift control valve to raise lift slightly, then disengage safety bar• Contact Hein-Werner repair center
Lift raises or lowers with jerky motion	<ul style="list-style-type: none">• Cylinder might need lubrication	<ul style="list-style-type: none">• Apply #630-AAA LUBRIPLATE to cylinder wall

REPLACEMENT PARTS

Not all components of the lift are replacement items, but are illustrated as a convenient reference of location and position in the assembly sequence. When ordering parts, give model number, part number and parts description. Call or write for current pricing: Hein-Werner Customer Support, 10939 N. Pomona Ave. Kansas City, MO 64153. Phone: (816)891-6390; E-mail: customerservices@heinwerner-automotive.com

Model HW93690

Item	Part#	Description	Qty.
1	N/A	Base Assy.	1
2	690-002-002	Wheel	2
3	690-002-003	Cotter Pin	2
4	690-002-004	Hex. Head Bolt	1
5	690-002-005	Hex. Nut	1
6*	690-002-006	Hex. Nut	1
7*	690-002-007	Hex. Head Bolt	1
8#	690-002-008	Ring (One Piece)	1
9	690-002-009	Seal Bearing	1
10#	690-002-010	Cup Seal	1
11	690-002-011	Washer	1
12*	690-002-012	Hex. Head Bolt	1
13	690-002-013	Air Valve Cover	1
14	690-002-014	Pipe Plug	1
15	690-002-015	Elbow Fitting	1

Item	Part#	Description	Qty
16	690-002-016	Air Line	1
17	690-002-017	Valve	1
18*	690-002-018	Hex. Nut	2
19	N/A	Lift Cylinder Assy.	1
20*	690-002-020	Hex. Bolt	1
21*	690-002-021	Hex. Nut	1
22	690-002-022	Grip	1
23	690-002-023	Saddle	2
24	690-002-024	Arm	2
25	690-002-025	Locking Pin	2
26	690-002-026	Roller	1
27	690-002-027	Locking Bolt	1
28	690-002-028	Caster	2
(#)	690-002-029	Repair Kit	-
(*)	690-002-099	Hardware Kit	-

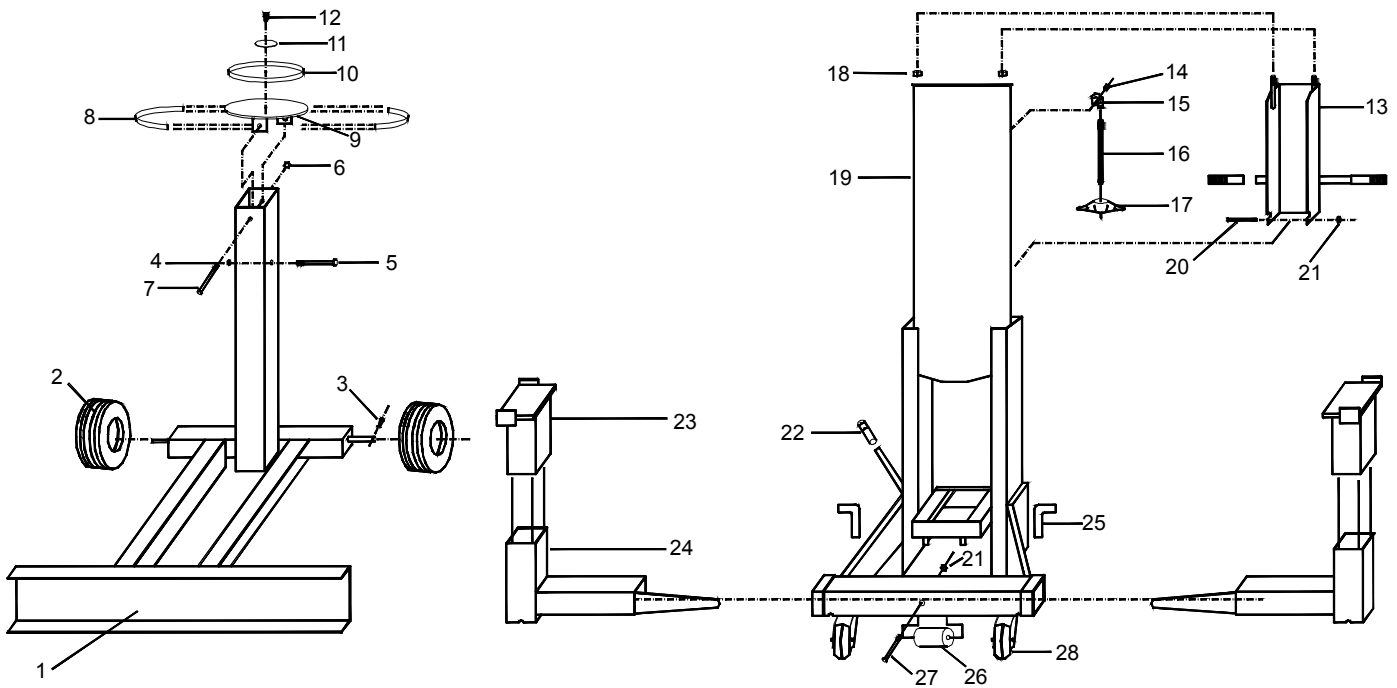

Figure 3 - Replacement Parts Illustration for Model HW93690



TWO YEARS LIMITED WARRANTY

For a period of two (2) years from date of purchase, SFA Companies will repair or replace, at its option, without charge, any of its products which fails due to a defect in material or workmanship under normal usage. This limited warranty is a consumer's exclusive remedy.

Performance of any obligation under this warranty may be obtained by returning the warranted product, freight prepaid, to SFA Companies Warranty Service Department, 10939 N. Pomona Ave., Kansas City, MO 64153. Except where such limitations and exclusions are specifically prohibited by applicable law:

- (1) THE CONSUMER'S SOLE AND EXCLUSIVE REMEDY SHALL BE THE REPAIR OR REPLACEMENT OF DEFECTIVE PRODUCTS AS DESCRIBED ABOVE
- (2) SFA COMPANIES SHALL NOT BE LIABLE FOR ANY CONSEQUENTIAL OR INCIDENTAL DAMAGE OR LOSS WHATSOEVER.
- (3) ANY IMPLIED WARRANTIES, INCLUDING WITHOUT LIMITATION THE IMPLIED WARRANTIES OF MERCHANTABILITY AND FITNESS FOR A PARTICULAR PURPOSE, SHALL BE LIMITED TO TWO YEARS, OTHERWISE THE REPAIR, REPLACEMENT OR REFUND AS PROVIDED UNDER THIS EXPRESS LIMITED WARRANTY IS THE EXCLUSIVE REMEDY OF THE CONSUMER, AND IS PROVIDED IN LIEU OF ALL OTHER WARRANTIES, EXPRESS OR IMPLIED.
- (4) ANY MODIFICATION, ALTERATION, ABUSE, UNAUTHORIZED SERVICE OR ORNAMENTAL DESIGN VOIDS THIS WARRANTY AND IS NOT COVERED BY THIS WARRANTY.

Some states do not allow limitations on how long an implied warranty lasts, so the above limitation may not apply to you. Some states do not allow the exclusion or limitation of incidental or consequential damages, so the above limitation or exclusion may not apply to you. This warranty gives you specific legal rights, and you may also have other rights which vary from state to state.

SFA Companies
10939 N. Pomona Ave. Kansas City, MO 64153
816-891-6390
customerservices@heinwerner-automotive.com