

METAL AIR PUMPS



PA1500



PA2000



PA3801



PA7550

- High strength reinforced alloy reservoir is lightweight and corrosion resistant
- Pressure relief valve for overload protection
- Suggested air pressure range: 110-175 psi / 7.5-12 bar
- Dust cover protection for the release control valve
- PA2000 offers a turbo function that features high flow at high pressure condition
- Maximum working pressure: 10,000 psi / 700 bar



Air pumps can be used in a variety of industrial settings

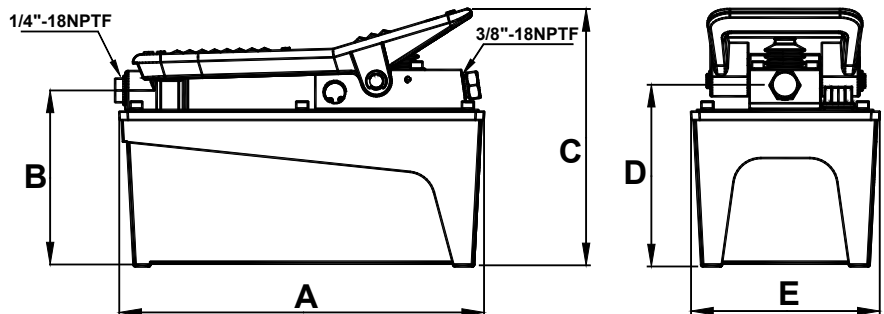
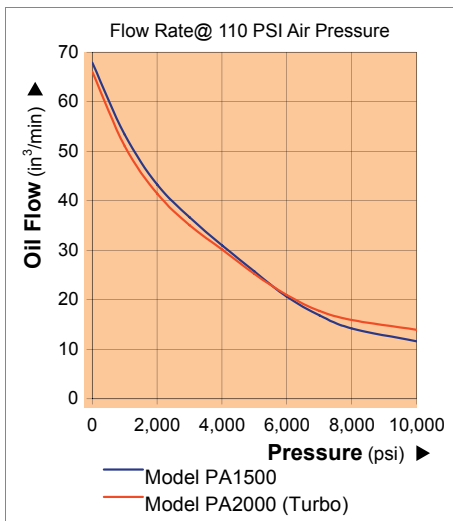

Used with Cylinder	Usable Oil Capacity (in ³)	Model Number	Pressure Rating (psi)	Oil Output Flow Rate (in ³ /min)		Input Air Pressure Range (psi)	Dimensions (in)					Weight (lbs)
				No Load	Load		A	B	C	D	E	
Single Acting	91.5	PA1500	10,000	66	11	110-175	10.35	5.00	7.28	5.16	5.35	18.1
	122.1	PA2000		65	12		11.57	6.02	7.91	6.18	5.98	20.1
	231.9	PA3801		65	11		12.64	5.08	7.36	5.24	7.36	27.1
	460.6	PA7550		65	11		12.64	5.398	8.31	6.14	8.43	36.0